



RadioShack®

www.radioshack.comSM

4-Channel Stereo Microphone Mixer



Owner's Manual

Please read before using this equipment.

□ Features

Your 4-Channel Stereo Microphone Mixer is a sophisticated control center, perfect for mixing sound from up to four audio input sources, such as a microphone, CD player, tuner, cassette player, or VCR. It is ruggedly constructed for home or professional use. The mixer's many features give you almost limitless sound combinations.

Its features include:

Eight Input Jacks — let you connect up to two stereo input sources (such as a tuner, cassette player, or CD player) or four mono input sources, and up to four microphones.

Four Output Jacks — let you connect up to two stereo output sources (such as an amplifier or a cassette recorder) or four mono output sources.



Four Wide-Range Sliding Controls — let you adjust the sound level of the four channels to achieve the right mix for playing through your speaker system or for recording.

Stereo/Monaural Modes — let you select either stereo or monaural output.

Dual Power Capability — lets you power your mixer from either a 9-volt battery or from an AC adapter.

Battery Low Indicator — lets you know when the battery needs to be replaced.

WARNING: To reduce the risk of fire or shock hazard, do not expose this product to rain or moisture.

| | | |
|--|---|---|
|  | CAUTION RISK OF ELECTRIC SHOCK. DO NOT OPEN. |  |
| CAUTION: TO REDUCE THE RISK OF ELECTRIC SHOCK, DO NOT REMOVE COVER OR BACK. NO USER-SERVICEABLE PARTS INSIDE. REFER SERVICING TO QUALIFIED PERSONNEL. | | |



This symbol is intended to alert you to the presence of uninsulated dangerous voltage within the product's enclosure that might be of sufficient magnitude to constitute a risk of electric shock. Do not open the product's case.



This symbol is intended to inform you that important operating and maintenance instructions are included in the literature accompanying this product.

□ Powering the Mixer

USING BATTERY POWER

You can power the mixer with a 9-volt battery (not supplied). For the best results and longest battery life, we recommend an alkaline battery, available at your local RadioShack store.

1. Use a flat-blade screwdriver to loosen the battery compartment cover's screw and remove the cover.

© 2000 RadioShack Corporation.
All Rights Reserved.

RadioShack and RadioShack.com are trademarks used by RadioShack Corporation.

- Attach the battery snap in the battery compartment to the 9-volt battery's terminals. Then place the battery in the compartment.
- Replace the cover and tighten the battery compartment cover's screw.

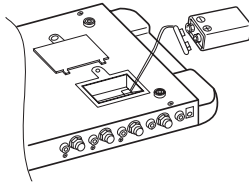

Replace the battery when the BATTERY LOW indicator on the mixer's upper right corner lights.

USING AC POWER

You can power the mixer using an optional 9V AC adapter (not supplied).

Cautions:



You must use a Class 2 power source that supplies 9V DC and delivers at least 300 mA.

Its center tip must be set to negative and its plug must fit the mixer's DC 9V jack. Using an adapter that does not meet these specifications could damage the mixer or the adapter.

- Always connect the AC adapter to the mixer before you connect it to AC power. When you finish, disconnect the adapter from AC power before you disconnect it from the mixer.

Follow these steps to connect the adapter.

- Insert the AC adapter's barrel plug into the DC 9V jack on the back of the mixer.

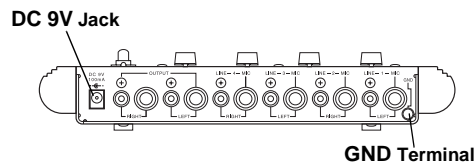

- Plug the AC adapter's power module into a standard AC outlet.

Preparation

PRESETTING THE CONTROLS

Presetting the Mixer

Warning: A sudden high output from the mixer could damage the audio devices connected to the mixer and your hearing, especially if you use headphones.

To avoid accidentally overdriving a channel or prematurely mixing in an audio input, ad-

just the mixer's controls to these settings before you turn on power.

| Control | Setting |
|--------------------|-------------|
| POWER | OFF |
| CHANNEL 1, 2, 3, 4 | 0 (Minimum) |
| MODE STEREO/MONO | MONO |

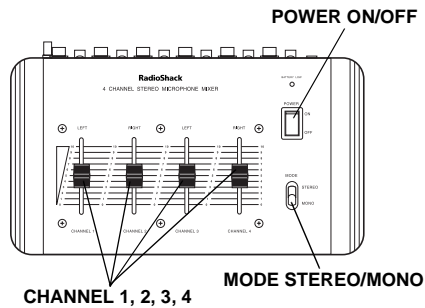

Presetting the Audio Devices

To avoid sudden and unusable sound outputs from the audio devices connected to the mixer's output, adjust the audio devices' volume controls to minimum and set their power controls to off before you connect the mixer's output jacks to the audio devices' input jacks.

MAKING THE CONNECTIONS

You can connect the line level outputs of several input sources (such as a CD player, a cassette player, the audio output of a VCR, a tuner, or other input source) to the mixer.

The **LINE** input jacks let you connect up to two stereo sources.

The **MIC** input jacks let you connect up to four microphones.

Note: Use shielded audio cables for all connections (available at your local RadioShack store).

Connecting Two Stereo Inputs

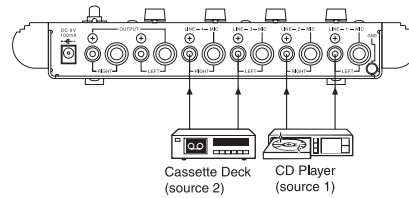

To connect two stereo sources, use the two pairs of **LEFT** and **RIGHT** phono input jacks (for example, use **LINE** jacks 1 (left) and 2 (right) for a CD player, and jacks 3 (left) and 4 (right) for a cassette player). The signals for each of these sources are routed to the corresponding output channel.

Connecting up to Four Stereo Sources as Monaural Inputs

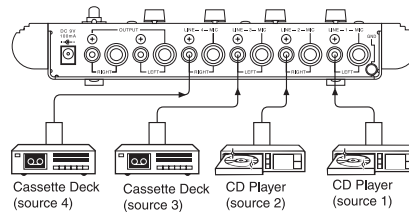

To connect up to four stereo sources as monaural inputs, using shielded Y-adapters at the sources' left and right outputs, connect a separate stereo source to each channel (**LINE** jacks 1 through 4). The signals for each of these sources are routed to the corresponding output channel.

Connecting up to Four Monaural Inputs

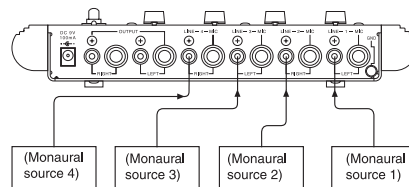

To connect up to four monaural sources, use **LINE** jacks 1 through 4 to connect a separate

monaural source to each channel. The signals of each of these sources are routed to the corresponding output channel.

Connecting Two Monaural Sources as Stereo Inputs

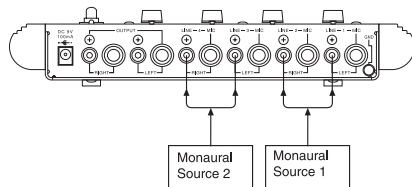

To connect two monaural sources as two stereo inputs, using shielded Y-adapters at the sources' monaural outputs, connect the other ends to the mixer's **LEFT** and **RIGHT** channels (for example, connect one monaural source to **LINE** jacks 1 and 2, and a second monaural source to **LINE** jacks 3 and 4). The signals for each of these sources are routed to the corresponding output channel.

Connecting up to Four Microphones

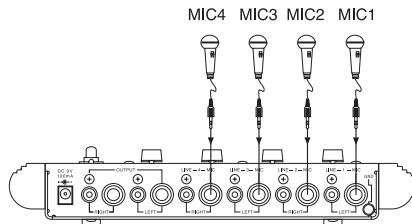

To connect up to four microphones, use **MIC** jacks 1 through 4. The signals for each of these sources are routed to the corresponding output channel.

Note: If you connect both **LINE** and **MIC** signal sources to the same channel, both signals are mixed and their levels are controlled by the corresponding channel's fader control.

Connecting the Outputs

To play the mixer's output signal through your speaker system (for events such as parties, dances, conferences, etc.), connect one end of an audio patch cord (not supplied) to the mixer's **OUTPUT LEFT** and **RIGHT** jacks and the other end of the audio patch cord to your receiver/amplifier's microphone input jacks.

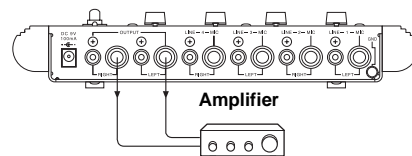

To record the mixer's output signal, connect one end of an audio patch cord (not supplied) to the mixer's **OUTPUT LEFT** and **RIGHT** jacks and the other end of the audio patch cord to your tape deck's microphone input jacks.

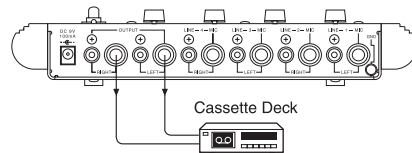

Notes:

- If you connect a PA system, attach a ground wire between its ground terminal (if it has one) and the mixer's **GND** terminal.

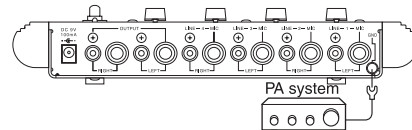

- If you have a monaural PA system or tape deck, use only one **OUTPUT** jack on the mixer and set the mixer's **MODE STEREO/MONO** switch to **MONO**.

□ Operation

After making all the necessary connections, follow these steps to operate your mixer.

1. Set **POWER ON/OFF** to **ON** to turn on the mixer.

Note: To avoid a possible popping sound, always turn on the mixer before you turn on the amplifier.

2. Turn on the output amplifier and leave its volume set to minimum.
3. Set the selected audio input source's volume to its minimum setting, turn it on, and set it to play (or continuously talk into the microphone).
4. Set the corresponding **CHANNEL 1**, **CHANNEL 2**, **CHANNEL 3**, or **CHANNEL 4** volume level to about **6 – 10**.

Notes:

- When mixing more than one audio input source, set all the volume level controls of the audio input sources to the same setting.
 - Adjust the mixer's fader controls to get the best mix. If the overall sound level is too low with the fader controls at **10**, increase the output amplifier's volume.
5. Adjust the output amplifier's volume level control to the desired volume.
 6. When you are finished mixing, set **POWER ON/OFF** to **OFF** and turn off the output amplifier and all the audio input sources.

MIXING MONO OR STEREO

When you set the mixer's **MODE STEREO/MONO** switch to **MONO**:

- The mixer routes the input signal of any monaural source connected to only one of the mixer's line inputs (**LEFT** or **RIGHT**) to both output channels.
- The mixer changes the stereo input signals connected to the mixer's line inputs (**LEFT** and **RIGHT**) to monaural.

To mix mono signals with stereo signals, set **STEREO/MONO** to **STEREO**.

Note: For mono amplifiers (found in some PA systems), it is best to set **MODE STEREO/MONO** to **MONO**.

VOICE-OVERS

You can mix an audio input source containing prerecorded music or special sounds while you talk into a microphone. This lets you mix your voice with music.

1. Set the mixer's fader controls for the music source you want to mix to the desired volume level (before you begin talking).
2. While the music plays, talk into the microphone and adjust the fader controls for the microphone and music source so you can hear yourself over the music.
3. During pauses in speech, return the music source's fader controls to their original positions.
4. When you finish speaking, set the microphone's fader control to **0** and the music source's fader controls to their original positions.

□ **Care**

Keep the mixer dry; if it gets wet, wipe it dry immediately. Use and store the mixer only in normal temperature environments. Handle the mixer carefully; do not drop it. Keep the mixer away from dust and dirt, and wipe it with a damp cloth occasionally to keep it looking new.

Modifying or tampering with the mixer's internal components can cause a malfunction and might invalidate its warranty. If your mixer is not performing as it should, take it to your local RadioShack store for assistance.

□ **Specifications**

Input Sensitivity:

Mic 1 mV
Line 100 mV
Output Level at 1 Kohm Load 1 mV

Input Overload:

Mic More than 250 mV
Line More than 6V
Distortion Less than 0.5%
Signal-to-Noise Ratio Better than 55 dB
Frequency Response 20–20,000 Hz \pm 2 dB

Power Requirements:

DC One 9V Battery
AC (Using AC Adapter) 120V AC, 60 Hz
Dimensions (HWD) $2^{3/16} \times 10^{5/8} \times 6^{5/16}$ Inches
(5.5 \times 27.0 \times 16.0 cm)
Weight 2 lbs 4.3 oz
(930 g)

Specifications are typical; individual units might vary. Specifications are subject to change and improvement without notice.

Limited One-Year Warranty

This product is warranted by RadioShack against manufacturing defects in material and workmanship under normal use for one (1) year from the date of purchase from RadioShack company-owned stores and authorized RadioShack franchisees and dealers. EXCEPT AS PROVIDED HEREIN, RadioShack MAKES NO EXPRESS WARRANTIES AND ANY IMPLIED WARRANTIES, INCLUDING THOSE OF MERCHANTABILITY AND FITNESS FOR A PARTICULAR PURPOSE, ARE LIMITED IN DURATION TO THE DURATION OF THE WRITTEN LIMITED WARRANTIES CONTAINED HEREIN. EXCEPT AS PROVIDED HEREIN, RadioShack SHALL HAVE NO LIABILITY OR RESPONSIBILITY TO CUSTOMER OR ANY OTHER PERSON OR ENTITY WITH RESPECT TO ANY LIABILITY, LOSS OR DAMAGE CAUSED DIRECTLY OR INDIRECTLY BY USE OR PERFORMANCE OF THE PRODUCT OR ARISING OUT OF ANY BREACH OF THIS WARRANTY, INCLUDING, BUT NOT LIMITED TO, ANY DAMAGES RESULTING FROM INCONVENIENCE, LOSS OF TIME, DATA, PROPERTY, REVENUE, OR PROFIT OR ANY INDIRECT, SPECIAL, INCIDENTAL, OR CONSEQUENTIAL DAMAGES, EVEN IF RadioShack HAS BEEN ADVISED OF THE POSSIBILITY OF SUCH DAMAGES.

Some states do not allow limitations on how long an implied warranty lasts or the exclusion or limitation of incidental or consequential damages, so the above limitations or exclusions may not apply to you.

In the event of a product defect during the warranty period, take the product and the RadioShack sales receipt as proof of purchase date to any RadioShack store. RadioShack will, at its option, unless otherwise provided by law: (a) correct the defect by product repair without charge for parts and labor; (b) replace the product with one of the same or similar design; or (c) refund the purchase price. All replaced parts and products, and products on which a refund is made, become the property of RadioShack. New or reconditioned parts and products may be used in the performance of warranty service. Repaired or replaced parts and products are warranted for the remainder of the original warranty period. You will be charged for repair or replacement of the product made after the expiration of the warranty period.

This warranty does not cover: (a) damage or failure caused by or attributable to acts of God, abuse, accident, misuse, improper or abnormal usage, failure to follow instructions, improper installation or maintenance, alteration, lightning or other incidence of excess voltage or current; (b) any repairs other than those provided by a RadioShack Authorized Service Facility; (c) consumables such as fuses or batteries; (d) cosmetic damage; (e) transportation, shipping or insurance costs; or (f) costs of product removal, installation, set-up service adjustment or reinstallation.

This warranty gives you specific legal rights, and you may also have other rights which vary from state to state.

RadioShack Customer Relations, 200 Taylor Street, 6th Floor, Fort Worth, TX 76102

We Service What We Sell

12/99