

**CM-5 COLOR MONITOR  
SHEET #2 (250-1023)  
FAXBACK DOC # 10377**

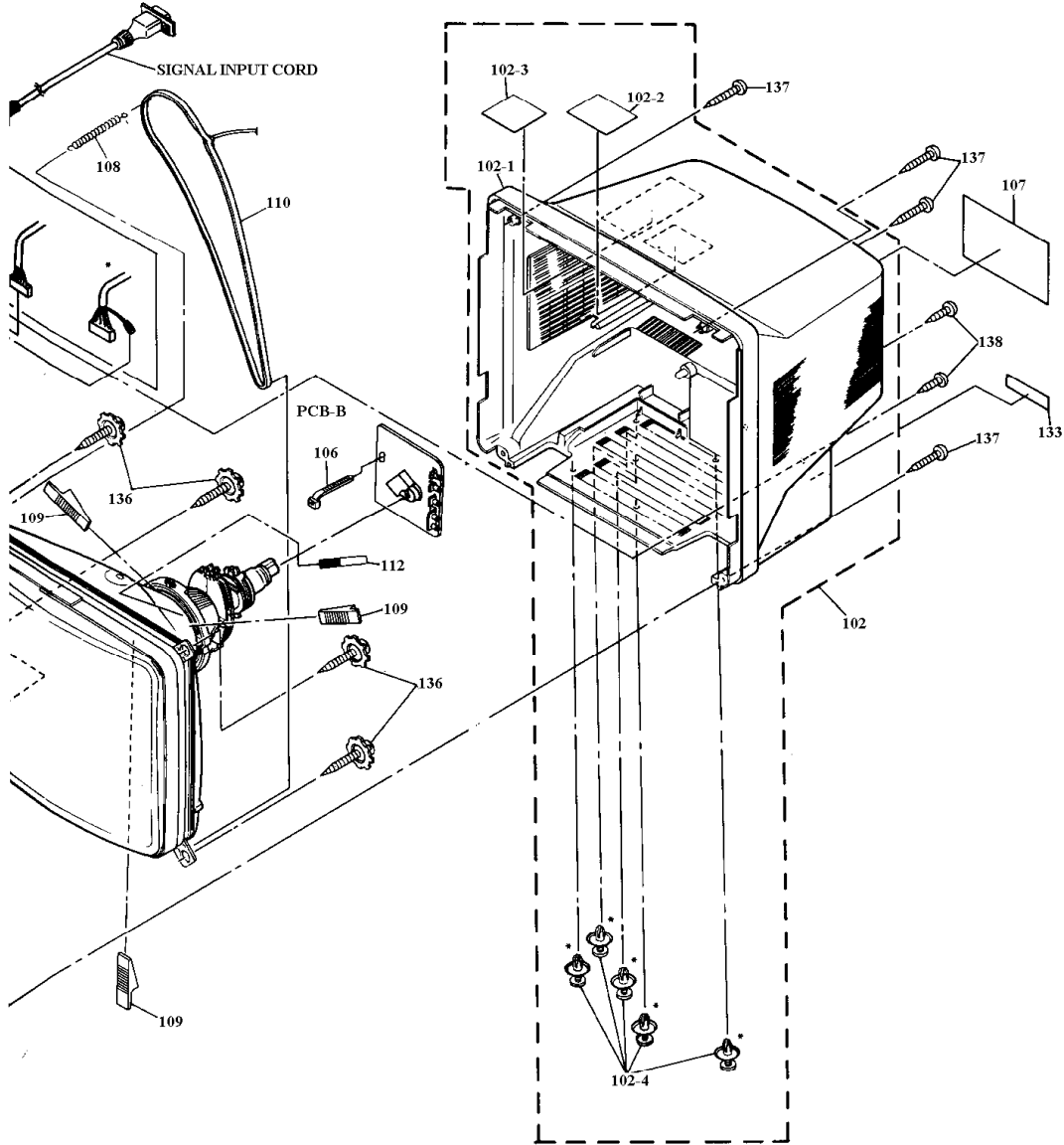

**CONTINUED ON  
SHEET # 1**